



ULTRA BRIGHT HID INDUSTRIAL LIGHT

BENEFITS:

- Luxtreme Series / **Extreme High Light Output** / Best at 4-6 meter Height
- Extremely Low Operation Cost / Energy Efficiency (50 VS 250W)
- **ONE HID/LED Module** / Natural Illumination
- Closest to Gas Tube Lighting / **No Ghost Effect**
- Fixture Acts as Heat Sink / LED is only 10C more than Surface
- Super Long Life / Zero Maintenance
- Simple Design / Solid Construct / Parts Easily Replaceable
- **Constant Current Design**
- Environmentally Friendly / No Toxic / Reduce Waste
- CO2 Reduction (Based on 50K Hours): **6699KG = 🌲 X 14**
- Mercury Reduction (compared to fluorescent): **41.67mg**
- Applications: Industries, Textile & Spinning, Exhibition Center, Airport, Railway Station, Hall Way, Warehouses etc..

The Light Revolution is Coming!

CUTES, HID Industrial Light are the next generation solution to replace conventional fluorescent light; they feature higher efficiency, more reliability compared to the previous generation. They are well suited for use anywhere, home, offices, museums, galleries, shop windows, hotels, restaurants, meeting rooms and as well as in industrial sector, just like conventional fluorescent lights.

Specification Features

Color Range	White, Warm White
Dimensions	Φ420mm x H270mm
Light Source	50W High Power LED
Housing	Die-casting aluminum
Operating Temperature	-40°C to 50°C (-40°F to 122°F)
Starting Temperature	-40°C to 50°C (-40°F to 122°F)
IP Rating	IP40
LED source life	50,000 hours
Design	Sling mounted
Accessory	Mounting chain
Weight	2.10kg

Physical Dimensions

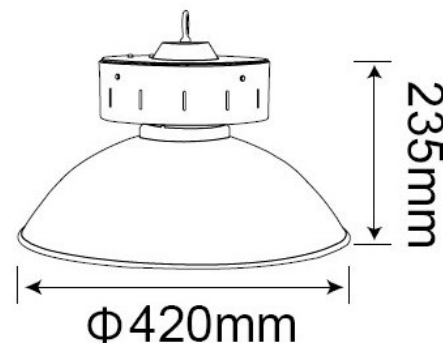

Electrical

Power Input	AC 110V/240V	Control Mechanism	None
DC Current	2.7A	Controller	None
Power Consumption	50W	Data Wiring	None

Optical

Lens	None
Beam Angle	120°
Light Distribution	Symmetric direct illumination

Light Output

Color	Wavelength (nm)	Color Temp. (Typical)	Light Output (Lm)	Efficacy (Lm/W)
White	-	5600~6000K	3900	65
Warm White	-	2800K 3000K 3300K	3600	60