

CAT SERIES

Single Stage Water Ring Vacuum Pump



Technical Data	
Pump type	CAT SERIES
Capacity CFM	600~2800
Noise dB(A)*	83~88
Weight KGs	1200~4600

* With silencer and after inlet and outlet piping in 200Torr.

Model Order Code		
CAT – 10 06 FCD 1M		
CAT	CUTES Corporation Double stages Liquid Ring Vacuum Pump - Conical cones design	
10	Capacity 1000CFM	
06	Operating Vacuum range	06 : cones with gas return slots
FCD	Material Construction Code. Ref. below table	
1M	Seal	Empty : Gland Packing 1M : Single Mech. Seal 2M: Double Mech. Seal

Parts Name	FCD								
Cones	FC25								
Head	FC25								
Housing	FC25								
Lining	----								
Shaft	S45C								
Cladding Plate	----								
Bearing Bracket	FCD40								
Bearing Cap	FCD40								
Rotor	FCD40								

Capacity

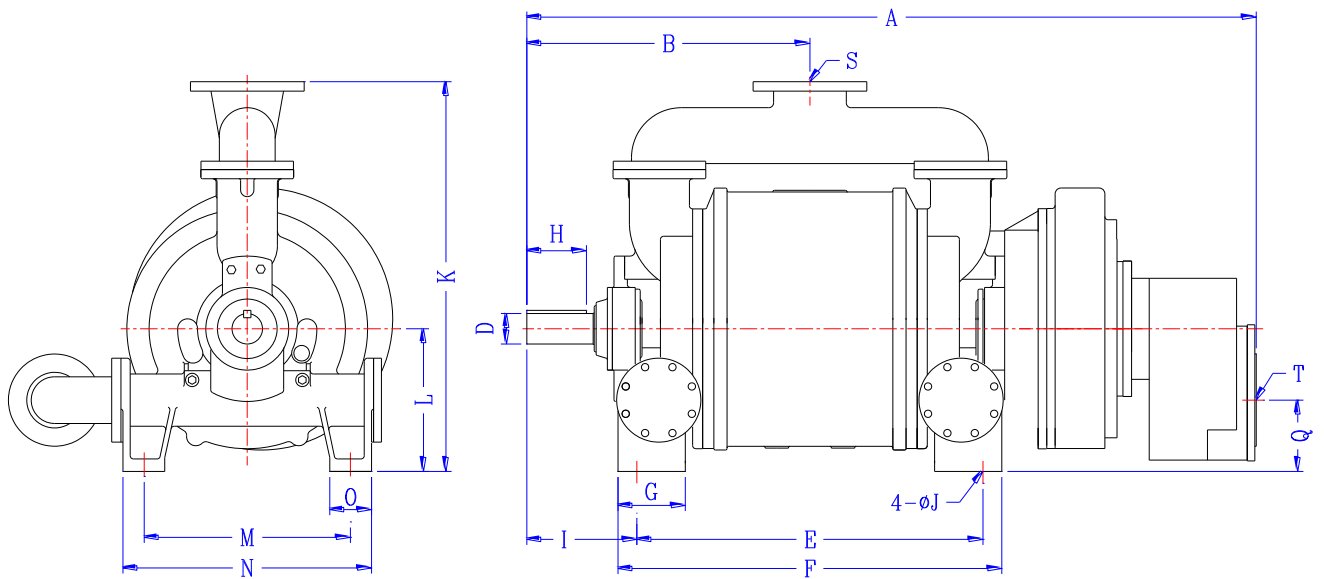
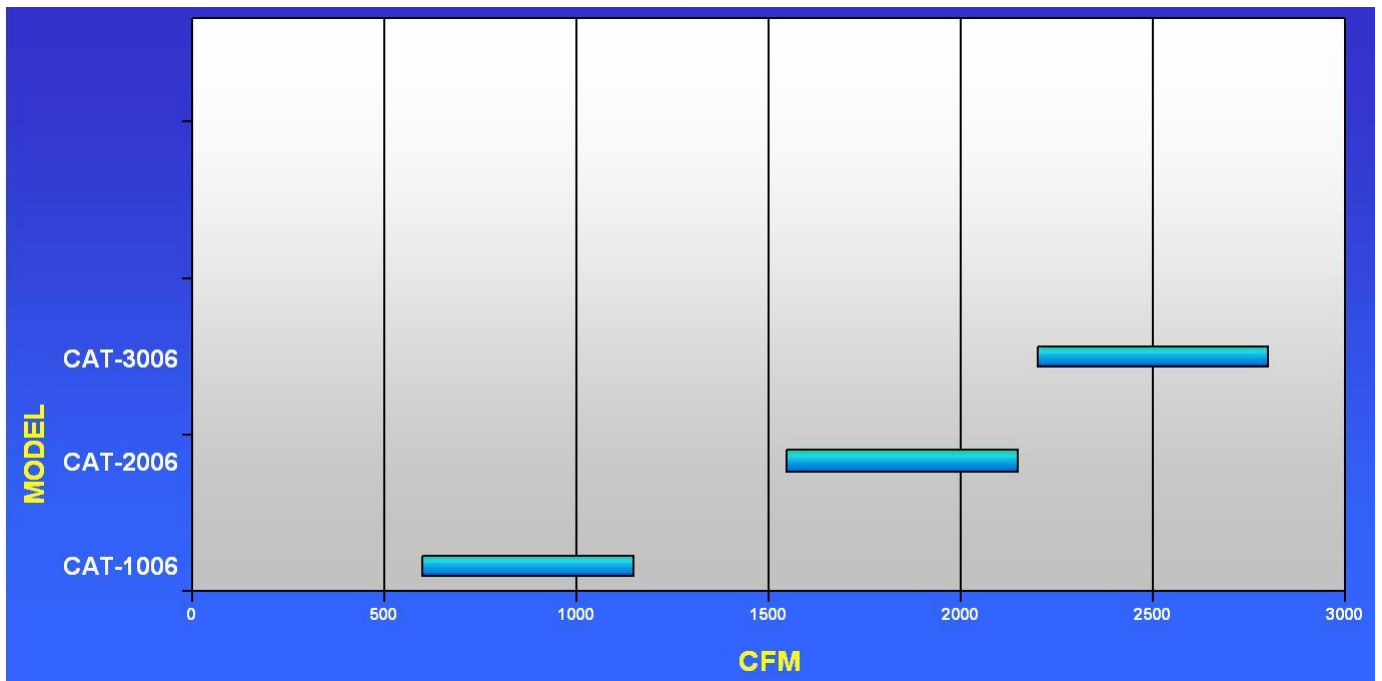

	A	B	D	E	F	G	H	I	J	K	L	M	N	O	Q	S	T	Piping
CAT-1006	1778	667	38.1	632	708	116	100	351	25	901	305	419	480	78	194	8"	5"	1"
CAT-2006	2200	854	92.75	1044	1158	203	180	332	32	1180	432	622	750	126	216	8"	6"	1"
CAT-3006	2515	978	101.6	1232	1344	222	200	362	32	1674	533	711	864	146	178	10"	8"	1"

Section Drawing

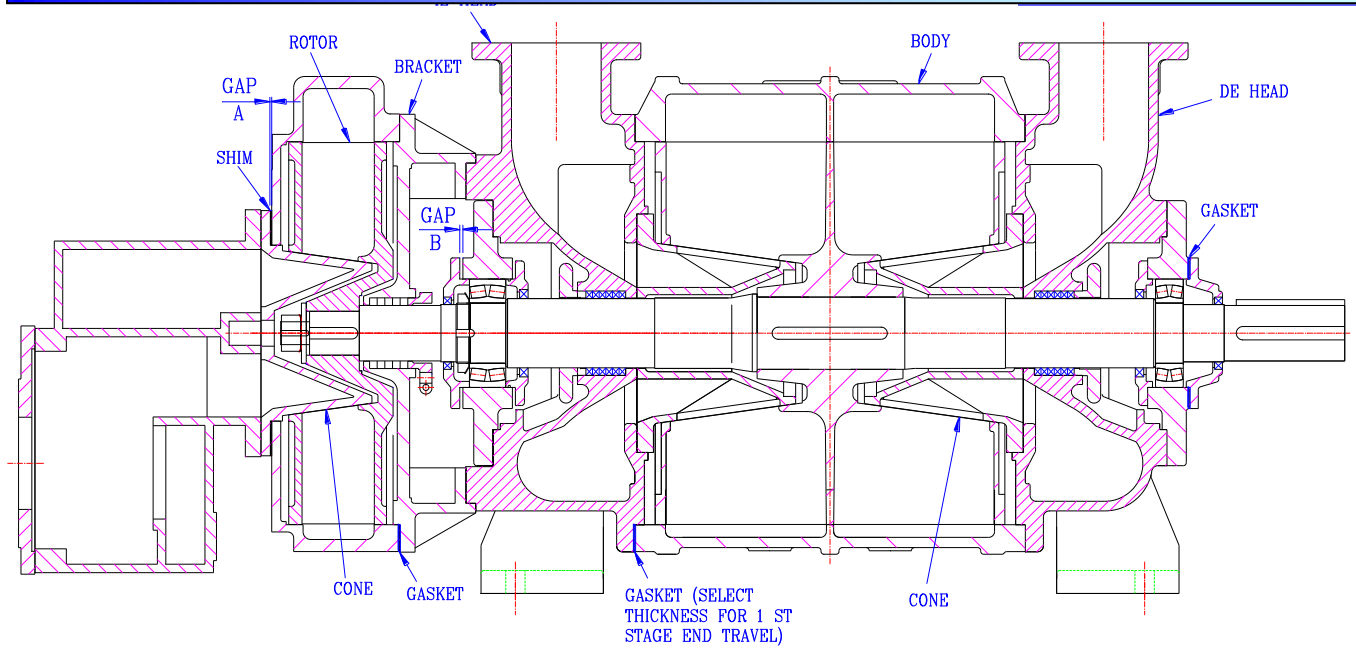

Exploded View

